

IZS60-1A

MICROFLUIDIC
TRANSFER

Industrial Syringe Pump



IZS60-1A

MICROFLUIDIC TRANSFER

Industrial Syringe Pump

Applied to bacterial culture, sampling detection, biological analysis, microfluidic chipAutomated pick chromosome analysis, DNA sequencing, etc.

Max flow :25mL/min



IZS30-1A

IZS60-1A is an industrial syringe pump independently developed by Chuangrui Pump Industry. It is driven by stepper motor and ground ball screw transmission piston. It provides a variety of sample injectors to choose from, suitable for different work requirements, original imported parts, durable Corrosion durable, long life, good anti-interference, suitable for industrial environment, provide RS232, RS485 communication control, support OEM customization.

High precision transmission

Driven by stepper motor, ground ball screw drive piston to ensure continuous and stable high-precision transmission.

Smart operation

Provide anti-collision alarm, error report, photoelectric encoder out-of-step detection and other functions.

Safe and reliable

Excellent electromagnetic compatibility and anti-interference, safer and more reliable operation, suitable for industrial environment.



Multiple injectors

Various types of syringes can be replaced, with a wide range of linear speeds and diverse applications.

Small size

Open integration, small size, easy matching, support OEM customization.

Original imported

The sampler, valve body and other wetted parts are imported with original, corrosion-resistant and durable, long service life.

Technical parameter

·Piston		
Working principle	Stepper motor drive, ball screw drive, rotary encoder to monitor displacement, with 0-bit detection	
Rated stroke	60mm corresponds to 6000 steps	
Linear speed range	50µm/sec – 50mm/sec (ie: 20 minutes slower for full stroke; 1.2 seconds faster for full stroke)	
Control resolution	1 step or 0.01mm	
Stroke control accuracy	When the stroke is greater than or equal to 30%, the error is less than or equal to 5‰	
Piston driving force	Maximum driving force ≥ 7kg; secondary driving force ≥ 3kg	
Injector type	50µl 100µl 250µl 500µl 1ml 2.5ml 5ml 10ml 25ml	
·Applicable valve		
Valve type	3 Port 120° Valve	
Transposition time	Transposition time of two adjacent ports ≤ 250ms	
Valve drive	Stepper motor drive, photoelectric encoder feedback position, out-of-step monitoring	
Valve material	Spool: Teflon Body: Teflon	
Valve interface	Tubing fitting: 1/4-28 thread fitting; Injector fitting: 1/4-28 thread fitting	
·External control interface		
Communication Interface	RS485 communication interface, communication rate: 9600 baud rate/38400 baud rate optional	
	RS232 communication interface, communication rate: 9600 baud rate/38400 baud rate optional	
External input interface	2 external TTL inputs with isolation; used to control start-stop after pause	
External output interface	3 external TTL outputs with isolation	
Device address dial interface	The device address can be set externally through the BCD dial	
Parameter jumper selection interface	Reserve 6 external jumper selection parameters (valve selection, communication rate selection, communication mode selection)	
·Software function		
Initialization command series	Complete the initialization state of valve and piston through various commands	
Parameter setting command series	Complete the setting of parameters such as speed, start slope, relative 0 point position, dead zone volume, etc. through different commands	
Valve Control Command Series	Complete movement of various valve positions	
Piston Control Command Series	Accurate displacement of the piston by different commands	
Control command series	Single, repeated, and delayed execution of single commands, combined command sequences, and stored command sequences through different commands; as well as suspending and terminating tasks, etc.	
Report command series	Through various commands, the valve position, piston position, piston driving force, piston speed and other states of the equipment can be monitored in real time	
Equipment dimensions	High	245mm
	Width	65mm
	Depth	150mm
Power Requirements	Voltage	24V DC
	Current	≥1.5A
Work environment requirements	Temperature	10℃-40℃
	Humidity	20%-95% at 40℃

Schematic diagram of structure and function

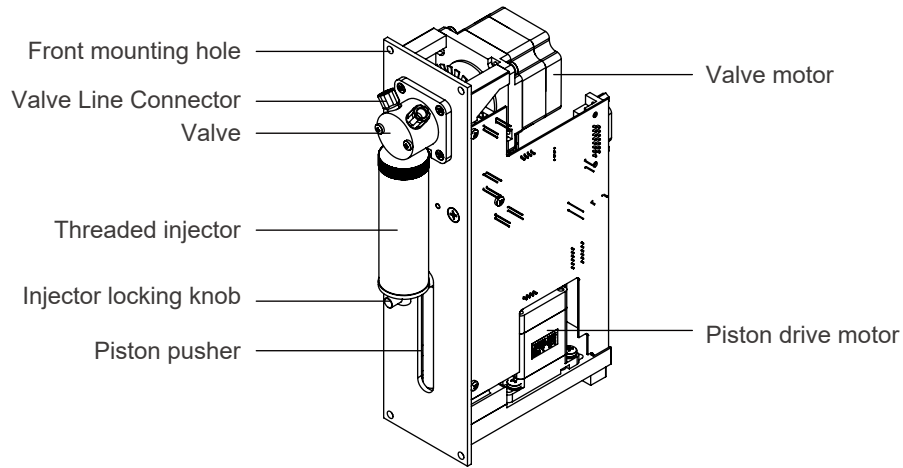

Dimensions

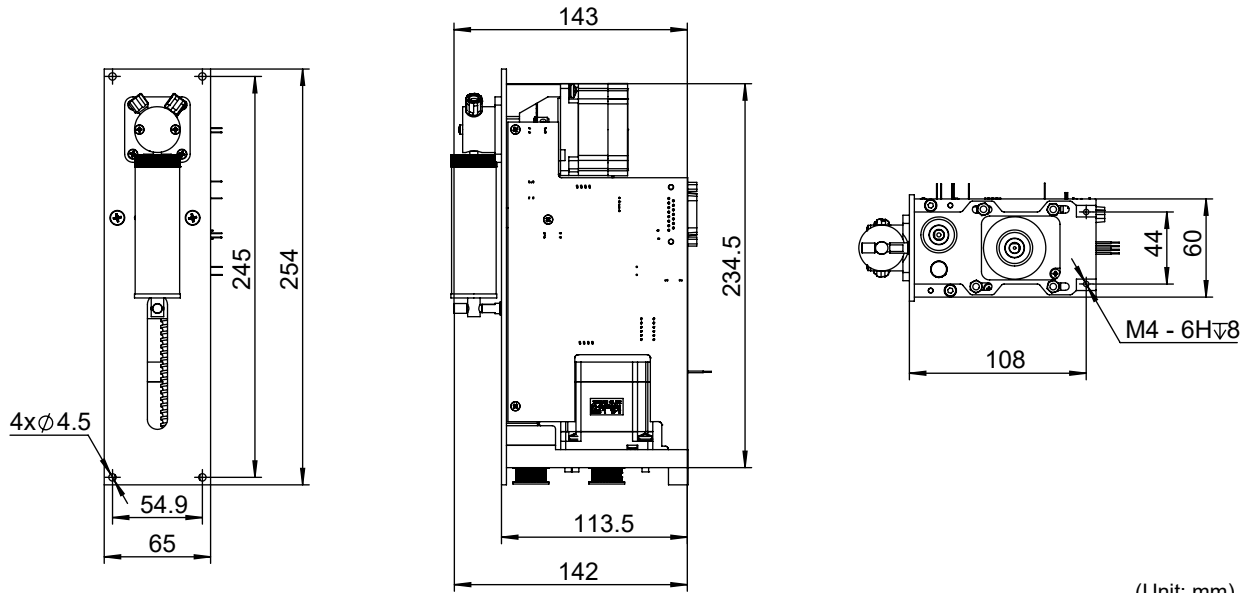

(Unit: mm)

CHONRY 创锐

Baoding Chuangrui Precision Pump Co.,Ltd.

Address: NO.369 of HuiYang Street , Baoding 071000,Hebei , China

Mobile: +86 15633705132

Website: <http://www.crpump.com>

Email: support@crpump.com

